

ENG

POSITION TRANSDUCERS



 **HYPERWAVE**
HIGH-PERFORMANCE MAGNETOSTRICTIVE TECHNOLOGY

GEFRAN

BEYOND TECHNOLOGY



GEFRAN

BEYOND TECHNOLOGY

More than fifty years of experience, an organisation with a strong focus on the customer's needs and constant technological innovation have made Gefran a benchmark in the design and production of sensors, systems and components for industrial process automation and control. Expertise, flexibility and process quality are the factors that distinguish Gefran in the production of integrated tools and systems for specific applications in various fields of industry, with consolidated know-how in the plastics, mobile hydraulics, heating and lift sectors.

Technology, innovation and versatility represent the catalogue's added value, in addition to the ability to create specific application solutions in association with the world's leading machine manufacturers.

POSITION TRANSDUCERS

Linear and angular position transducers detect the position of mechanical parts in motion. Real-time position detection makes it possible to reduce machine cycle times and to intercept points for actuation of other servomechanisms in the stroke.

For example by introducing acceleration and deceleration ramps, Gefran has adopted a number of technologies for transduction of position measurement:

- POTENTIOMETRIC of military origin, in which the resistive and collector track are electrically connected by means of contact brushes mounted on the spool.
- MAGNETOSTRICTIVE HYPERWAVE uses the magnetic characteristic and micro-elastic deformation of the primary element to pinpoint the exact position of the cursor.
- HALL EFFECT uses the sinusoidal intersection of magnetic fields to determine the angular position.
- MEMS technology calculates the angle of inclination in the three axes X, Y, Z with respect to the earth's axis.



HYPERWAVE
HIGH-PERFORMANCE MAGNETOSTRICTIVE TECHNOLOGY
MAGNETOSTRICTIVE
WPG, WRG, WPA



POTENTIOMETERS LT, PC



ROTARY GRA, GRN



INCLINOMETERS GIG, GIT, GSF, GSH

Gefran position transducers are made of robust materials that allow them to be used in most industrial applications, even in particularly adverse conditions.

The body of the position transducers is made of various materials such as anodised aluminium, AISI 316 stainless steel or PBT plastic, which mainly used in the automotive sector, and also resistant to UV rays, saline mist, acids and other aggressive agents.

Gefran position transducers are the result of years of experience and close collaboration with the best European research universities and research centres. Each transducer has been designed and manufactured with features aimed at satisfying the requirements of its particular application.

APPLICATION SECTORS



PLASTIC AND RUBBER
INJECTION PRESSES



METALWORKING



MATERIALS
HANDLING



HYDRAULIC AND
PNEUMATIC CYLINDERS



RENEWABLE
ENERGIES

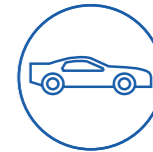

AUTOMOTIVE TESTING
MACHINES



MEDICAL
SECTOR

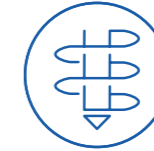

GEOTECHNICS



LEVEL
CONTROL



FARMING AND
EARTHMOVING
MACHINERY



RAILWAYS



NAVAL

MAIN FEATURES

- Absolute position measurement: when the system is switched on, the transducer immediately provides the actual position, with no need for mechanical repositioning.
- Lifespan: from 100 million manoeuvres of potentiometric transducers to the practically unlimited lifespan of HYPERWAVE MAGNETOSTRICTIVE transducers or HALL EFFECT transducers, thanks to the absence of contact between the transducer and its position reader.
- High resolution of the output signal: from virtually infinite for potentiometers to 0.5p for magnetostrictive transducers.
- Easy installation and simple connection to the most common instruments and PLCs.
- Possibility of simultaneously managing up to 16 position readers with the same transducer and providing the displacement speed (MK4 series magnetostrictive in Profinet).
- Sensors guaranteed up to 2 years (5 years magnetostrictive model WPA, WRA, WPP/WRP, WPL, WPA-F).



POTENTIOMETERS PME, PZ34, PV1

ANALOGUE AND DIGITAL INFORMATION

GEFRAN manufactures both transmitters and transducers with the following electrical outputs:

ANALOGUE

- Ratiometric
- Voltage divider 1 to 60Vdc
- 0...20mA, 4...20mA
- 0.5...4.5Vdc, 0...5Vdc, 0...10Vdc



DIGITAL

- SSI with 16, 21, 24, 25 bit binary or gray code output data format
 - Position resolution up to 0.5μ
 - Sampling time 250 msec
- IO-Link with digital output format 32 bit position, 16 bit speed, 2 bit SSC
 - 5, 10, 20, 50, 100pm resolution
 - Sampling time 1 msec
 - Speed data resolution 0.5 mm/sec
 - Setting of 2 cams or shut-off thresholds (Single/Two/Window)
- DPV0 Profibus interface on RS485 according to IEC 61158T
 - Position resolution settable via software up to 1 μm
 - Speed resolution up to 0.25 mm/sec
 - Position and speed measurement with up to 4 cursors
 - Setting of 4/8 cams or shut-off thresholds
- Profinet RT (real time) & IRT (Isochronous Real time) interface (ver. 2.3)
 - General or Encoder profile vr. 4.2
 - Position resolution settable via software up to 0.5 μm
 - Speed resolution up to 0.25 mm/sec
 - Position and speed measurement up to 16 cursors
 - Number of Work Hours, Maximum and real temperature, active cursor control
- CANopen CiA DP 3.01 rel.4.0 and DS406 with the following special features
 - Selectable baud rate from 10KBaud to 1MBaud
 - Real-time resolution switching (2 to 40ms)
 - Position and speed measurement of 1 or 2 cursors
 - Setting 4/8 cams or shut-off thresholds
- Can SAE J1939 multi-PDU approach (CiA 602-2)
 - 14 bit digital resolution



STROKES FROM 10mm A 8300mm

MAGNETOSTRICTIVE TECHNOLOGY

The evolution of the rectilinear potentiometric transducer is represented by magnetostrictive position transmitters in which there is no contact between the transducer and its cursor. The measuring element consists of a special alloy tube flanked by a copper conductor. The measurement process takes place through the interaction of mechanical waves and electromagnetic fields. The sensor electronics send a 3Ampere current pulse down the tube for a duration of 3 microseconds; the interaction between the current pulse and the magnetic field generated by the position magnet creates a torsion that spreads across the magnetostrictive guide wire in the form of a torsional mechanical wave. By measuring the time between sending the electrical excitation signal and detecting the sonic wave on the magnetostrictive return wire, the exact position of the magnet can be calculated down to the nearest micron.

The sonic wave travels over the magnetostrictive element at approximately 2850 metres/second and the position information is updated an average of 1000 times in one second.

Thanks to this technology there is no direct contact between the moving parts and therefore no wear on the transducer.

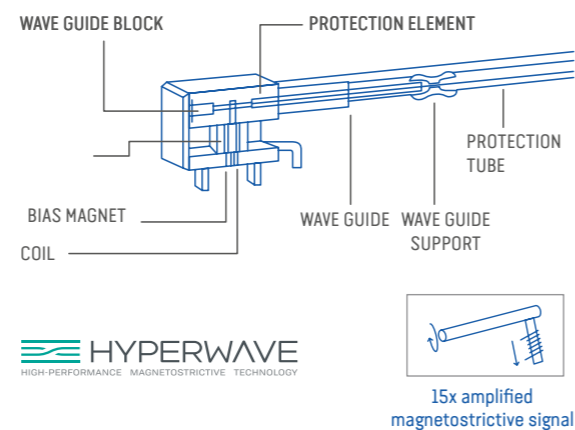

HALL EFFECT TECHNOLOGY

A Hall effect sensor is a transducer that varies its output voltage in response to a magnetic field. Hall effect devices are used as proximity and positioning sensors. **This is a more reliable and durable solution to a mechanical switch, as there are no problems with the wear.** The Hall effect refers to the voltage that can be measured across a conductor (or semiconductor) when an electric current flowing through it is affected by a magnetic field. Under these conditions a transverse voltage is generated perpendicularly to the applied current, due to the balancing of the Lorentz and electrical forces. Small size of the integrated package reduces system space and the associated mechanical complexity of implementation.

The Hall effect sensor detects the magnetic field and produces an analogue or digital signal, which is converted into a standard signal, depending on the requirements of the electronic system. Creation of a voltage (VH) across a conductor carrying a current and subjected to a magnetic field is known as the Hall effect, after the American physicist Edwin Hall, who discovered it in 1879.

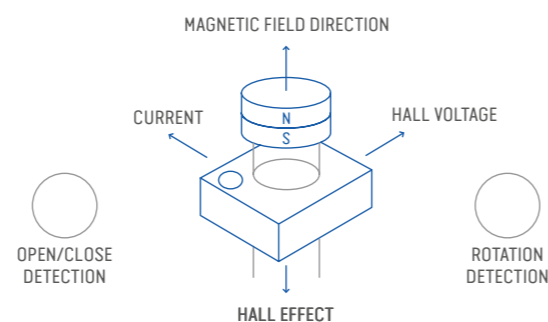

POTENTIOMETRIC TECHNOLOGY

The key element in potentiometric transducer consists of two linear tracks, both of which are the same length as the maximum displacement to be measured and made of a conductive material. A movable cursor with two connected sliding contacts (brushes) acts as a bridge between the two tracks, and measures the potential difference between the first, resistive track and the second, conductive track.

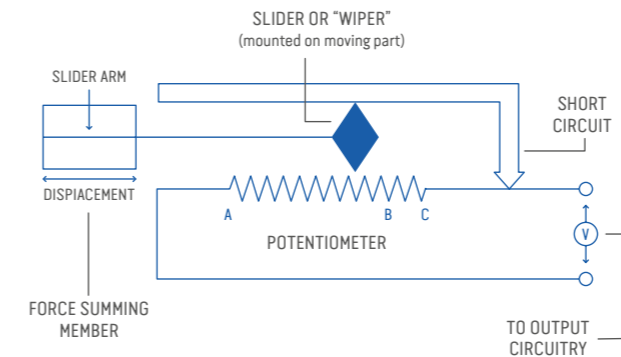

The cursor may be external to the device, and therefore connectable as long as directly to the moving object, whose displacement is to be measured, or it may be internal: a rod, or stem, is used as the actuator of the external movement on the potentiometer cursor. To ensure a high degree of measurement accuracy, it is essential to ensure high quality of the resistive track. Only in this way will the position of the contact on the track correspond to an accurate and repeatable voltage output value. **Gefran manufactures all the resistive tracks of its potentiometric transducers in-house, and is therefore able to guarantee measurement reliability and precision.** The relative simplicity of this type of technology allows it to be used in models with a small footprint. Gefran potentiometers do not require any control logic and are therefore quick and easy to install.

MEMS TECHNOLOGY

MEMS stands for Micro Electro-Mechanical Systems and is one of the most promising technologies of the 21st century, revolutionising the design paradigms of electronic and computer systems. **As a result of this technology, it has been possible to bring electromechanical functions that could previously only be implemented with electrotechnical technologies down to the nanometric level, thus reducing consumption.** Sensors were the first practical application of MemS technology. A perfect example of the application of this technology is the inclinometer for controlling angular orientation on the X/Y and Z axes with respect to the earth's axis.

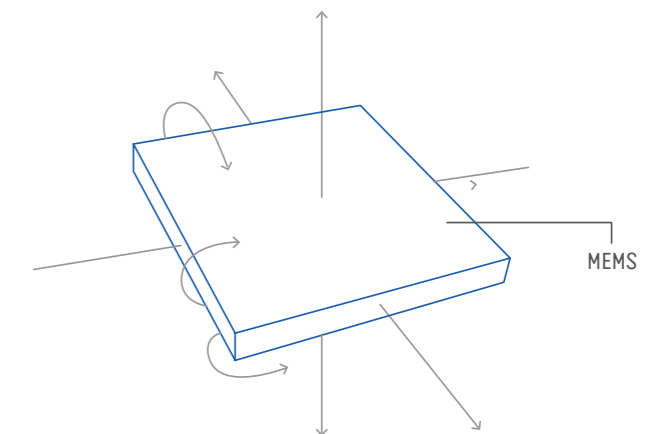

TRANSDUCER SELECTION GUIDE

LENGTH OR ANGLE TO BE MEASURED

GEFRAN transducers can be used to detect linear displacements on strokes from a minimum of 10 mm to a maximum of 8300 mm, or angular measurements ranging from +10° to +-180°.

It should always be kept in mind that two strokes are normally specified:

- **Mechanical stroke:** This is the effective translation that the transducer cursor can make;
- **Useful electrical stroke:** this is the part of the mechanical stroke in which the linearity of the transducer is guaranteed.

This means that when studying the application, it is necessary to choose a transducer with a useful electrical stroke equal to or greater than the maximum movement of the moving part.

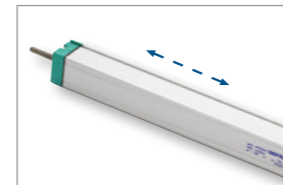

LT

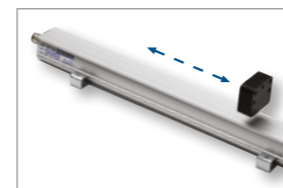

WPA

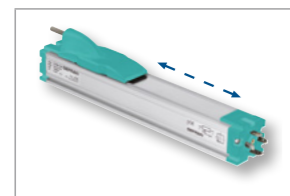

PK

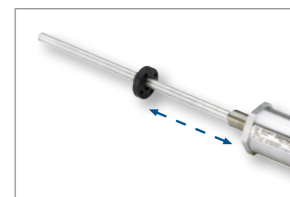

WRA

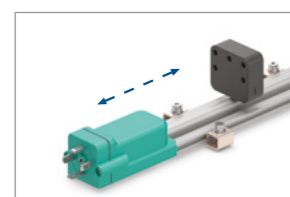

WPG

TYPES OF POSITION DETECTION

In order to make it possible to detect the movement of an object, the transducer is structured with a moving part, which is normally attached to the object itself.

This moving part is usually of two types:

- **rod:** this is the classic system used by potentiometers and consists of a rod that retracts into the body of the transducer, reporting the movement to the sensor's internal parts;
- **cursor:** this is a more compact solution using a cursor that becomes an integral part of the moving part to be detected.

It is available on some potentiometers (PK, PME and PMI series) as well as on most magnetostrictives. (WRG-A, WPP-A, WPP-S, WPA-A, WPA-S...)

Note that the cursor may be guided (slide or ring) or completely free in relation to the transducer (floating magnetic cursor).

GEFRAN TRANSDUCERS AND INSTRUMENTS: THE WINNING COMBINATION

Gefran instrumentation and position transducers are the best solution for detecting the position of moving mechanical parts.

GEFRAN instruments are designed with user-configurable digital inputs in mV/V, voltage and current.



ANCHORAGE SYSTEM

The transducer can be mounted using three types of support:

- **brackets:** this is the most traditional method; it requires a free surface on which to install the transducer and involves use of two or more brackets, depending on the length of the sensor;
- **flanges:** ideal in applications where the stem must pass through a borehole and the transducer must be fixed to the walls of the borehole; in this case, care must be taken with the conditions of use, especially in the case of high strokes;
- **self-aligning joints:** used to fasten the ends of the transducer directly to the moving parts; this eliminates other fastening points and allows offset movements to be detected; this system is not intended for excessively long strokes.

	BRACKETS	FLANGE	SELF-ALIGNING JOINTS
MAGNETOSTRICTIVE	WPG-A	WRG-A	RK-XL319
	WPP-A	WRP-A	
	WPP-S	WRP-S	
	WPA-A	WRA-A	
	WPA-S	WRA-S	
	WPL-A	WRA-F	
	WPA-F	IK4-C	
	MK4-C	IK4-P	
	MK4-P	RK2	
		RK4	
POTENTIOMETERS	LT/LT67	IC	PC/PC67
	PZ12	PZ12	PZ12
	PZ34/PZ67	PZ34/PZ67	PZ34/PZ67
	PK	PMI2	PMA12
	PA1	PMI-SL/PMI-SLE	
	PY1		
	PY2		
	PY3		
	PZ12		
	PME12		
PS09			
PS11			
PS20			
PR65			
HALL EFFECT		GSF	
		GSH	
		GRA	
		GRN	
INCLINOMETERS		GIB	
		GIG / GIG RELAY	
	GIT		

MAGNETOSTRICTIVE POSITION TRANSDUCERS

MAIN TECHNICAL CHARACTERISTICS



MODEL	WPG-A	WPP-A	WPP-S	WPA-A
USEFUL ELECTRICAL STROKE	50...1500 mm	50...2500 mm	50...2500 mm	50...4000 mm
INDEPENDENT LINEARITY	±0.02%	±0.02%... ±0.04%	±0.02%	±0.01%... ±0.04%
RESOLUTION	infinite (limited only by output noise)	16 bit (Max. noise 5 mVpp)	20 µm - 40 µm	16 bit (Max. noise 5 mVpp)
REPEATABILITY	≤0.01 mm	<0.01 mm	<0.02 mm	<0.01 mm
SAMPLING TIME	1 ms to 3 ms (depending on stroke)	0.5 ms to 2 ms (depending on stroke)	0.5 ms to 4 ms (depending on stroke)	0.5 ms to 3 ms (depending on stroke)
PROPERTIES OF MEASUREMENT PRINCIPLE	Magnetostrictive ultrasonic time measurement (system without physical contact)	Magnetostrictive ultrasonic time measurement (system without physical contact)	Magnetostrictive ultrasonic time measurement (system without physical contact)	Magnetostrictive ultrasonic time measurement (system without physical contact)
OPERATING TEMPERATURE	-20...+75°C	-30...+75°C	-30...+90°C	-30...+85°C
STORAGE TEMPERATURE	-40...+100°C	-40...+100°C	-40...+100°C	-40...+100°C
POSITION READER SHIFT SPEED	≤10 m/s	≤10 m/s	≤10 m/s	≤10 m/s
SLIDING CURSOR SHIFT FORCE	≤1N	≤1N	≤1N	≤1N
LIFESPAN	Theoretically unlimited	Theoretically unlimited	Theoretically unlimited	Theoretically unlimited
TRANSDUCER BODY CONSTRUCTION MATERIAL	Anodised aluminium nylon 66 gf 40	Anodised aluminium Nickel-plated zamak	Anodised aluminium Nickel-plated zamak	Anodised aluminium Nickel-plated zamak
POSITION READER CONSTRUCTION MATERIAL	Magnetic cursor nylon 66 gf 40 floating sliding cursor	Magnetic cursor nylon 66 gf 40 floating sliding cursor	Magnetic cursor nylon 66 gf 40 floating sliding cursor	Magnetic cursor nylon 66 gf 40 floating sliding cursor
ELECTRICAL CONNECTIONS	WPG-A-M Conn. 4 poles EN175301-803* WPG-A-A Conn. 5 poles M12	WPP-A-A Conn. 5 poles M12 M. WPP-A-B Conn. 6 poles M16 M. WPP-A-C Conn. 8 poles M16 M. WPP-A-H Conn. 8 poles M12 M. WPP-A-F 6-wire PVC cable 1 m. WPP-A-F 6-wire PVC cable 1 m.	WPP-S-B Conn. 6 poles M16 M. WPP-S-C Conn. 8 poles M16 M. WPP-S-D Conn. 7 poles M16 M. WPP-S-H Conn. 8 poles M12 M. WPP-S-F 6-wire PVC cable 1 m. WPP-S-R 7-wire PUR cable 1 m.	WPA-A-A Conn. 5 poles M12 M. WPA-A-B Conn. 6 poles M16 M. WPA-A-C Conn. 8 poles M16 M. WPA-A-H Conn. 8 poles M12 M. WPA-A-F 6-wire PVC cable 1 m. WPA-A-R PUR cable 7 wires 1 m.
OUTPUT SIGNALS	Analogue 1 cursor position	Analogue 2 position and speed cursors	SSI 1 position cursor	Analogue 2 position and speed cursors
PROTECTION RATING	IP67	IP67	IP67	IP67
MECHANICS AND ANCHORAGE	Mechanical drive with joint for taking up play or with floating magnet cursor. Brackets with variable centre-to-centre distance	Mechanical drive with joint for taking up play or with floating magnet cursor. Brackets with variable centre-to-centre distance	Mechanical drive with joint for taking up play or with floating magnet cursor. Brackets with variable centre-to-centre distance	Mechanical drive with joint for taking up play or with floating magnet cursor. Brackets with variable centre-to-centre distance
HOUSING SIZE/LENGTH	204 ... 1654 mm	204 ... 2654 mm	204 ... 2654 mm	204 ... 2654 mm



MODEL	WPA-S	WPL-A	MK4-C	MK4-P	WPA-F
USEFUL ELECTRICAL STROKE	50...4000 mm	50...4000 mm	50...4000 mm	50...4000 mm	50...4000 mm
INDEPENDENT LINEARITY	±0.01%... ±0.02%	±0.01%... ±0.02%	±0.02%... ±0.04%	±0.01%... ±0.02%	±0.01%... ±0.02%
RESOLUTION	0.5 µm - 40 µm	5, 10, 20, 50, 100 µm	2 µm - 40 µm	1 µm	0.5 µm
REPEATABILITY	<0.01 mm	<0.01 mm	<0.01 mm	<0.01 mm	<0.01 mm
SAMPLING TIME	0.5 ms to 4 ms (depending on stroke)	0.5 ms to 4 ms (depending on stroke)	1 ms to 4 ms (depending on stroke)	1 ms to 4 ms (depending on stroke)	0.5ms to 3ms (depending on stroke)
PROPERTIES OF MEASUREMENT PRINCIPLE	Magnetostrictive ultrasonic time measurement (system without physical contact)	Magnetostrictive ultrasonic time measurement (system without physical contact)	Magnetostrictive ultrasonic time measurement (system without physical contact)	Magnetostrictive ultrasonic time measurement (system without physical contact)	Magnetostrictive ultrasonic time measurement (system without physical contact)
OPERATING TEMPERATURE	-30...+90°C	-30...+90°C	-30...+75°C	-40...+85°C	-40...+85°C
STORAGE TEMPERATURE	-40...+100°C	-40...+100°C	-40...+100°C	-40...+100°C	-40...+100°C
POSITION READER SHIFT SPEED	≤10 m/s	≤10 m/s	≤10 m/s	≤10 m/s	≤10 m/s
SLIDING CURSOR SHIFT FORCE	≤1N	≤1N	≤1N	≤1N	≤1N
LIFESPAN	Theoretically unlimited	Theoretically unlimited	Theoretically unlimited	Theoretically unlimited	Theoretically unlimited
TRANSDUCER BODY CONSTRUCTION MATERIAL	Anodised aluminium Nickel-plated zamak	Anodised aluminium Nickel-plated zamak	Anodised aluminium Nickel-plated zamak	Anodised aluminium Nickel-plated zamak	Anodised aluminium Nickel-plated zamak
POSITION READER CONSTRUCTION MATERIAL	Magnetic cursor nylon 66 gf 40 floating sliding cursor	Magnetic cursor nylon 66 gf 40 floating sliding cursor	Magnetic cursor nylon 66 gf 40 floating sliding cursor	Magnetic cursor nylon 66 gf 40 floating sliding cursor	Magnetic cursor nylon 66 gf 40 floating sliding cursor
ELECTRICAL CONNECTIONS	WPA-S-B Conn. 6 poles M16 M. WPA-S-C Conn. 8 poles M16 M. WPA-S-D Conn. 7 poles M16 M. WPA-S-H Conn. 8 poles M12 M. WPA-S-F 6-wire PVC cable 1 m. WPA-S-R 7-wire PUR cable 1 m.	WPL-A-A Conn. 5 poles M12 M.	MK4-C-B Conn. 5 poles M12 M. MK4-C-A Conn. 6 poles M16 M. MK4-C-F 4-wire cable 1 metre	MK4P-W Conn. 5-poles M12 F. MK4P-W Conn. 4-poles M8 M. MK4P-W Conn. 5-poles M12 M.	WPA-F Conn. 5-poles M12 F. (cod. D) WPA-F Conn. 4-poles M8 M. (cod. A) WPA-F Conn. 5-poles M12 M. (cod. D)
OUTPUT SIGNALS	SSI 1 position cursor	IO Link 1 position, speed, SSC cursor	CANopen 2 position and speed cursors, 4 digital cams	PROFIBUS 4 position and speed cursors, 4 digital cams	PROFINET 16 position and speed cursors (General Profile) 1 position and speed cursors (Encoder Profile)
PROTECTION RATING	IP67	IP67	IP67	IP67	IP67
MECHANICS AND ANCHORAGE	Mechanical drive with joint for taking up play or with floating magnet cursor. Brackets with variable centre-to-centre distance	Mechanical drive with joint for taking up play or with floating magnet cursor. Brackets with variable centre-to-centre distance	Mechanical drive with joint for taking up play or with floating magnet cursor. Brackets with variable centre-to-centre distance	Mechanical drive with joint for taking up play or with floating magnet cursor. Brackets with variable centre-to-centre distance	Mechanical drive with joint for taking up play or with floating magnet cursor. Brackets with variable centre-to-centre distance
HOUSING SIZE/LENGTH	204 ... 4154 mm	204 ... 4154 mm	204 ... 4154 mm	232 ... 4182 mm	235 ... 4185 mm

CURSORS - POSITION READERS

WPG SERIES



PCUR220



PCUR221



PCUR222



PCUR202

WPP / WPA SERIES



PCUR210



PCUR211



PCUR212



PCUR202

MK4 SERIES



PCUR035



PCUR036



PCUR037



PCUR039

ANCHORAGE BRACKETS



WPG SERIES

PKIT590 int. 50mm
PKIT591 int. 42.5mm



WPP / WPA / MK4 SERIES

PKIT090 int. 50mm
PKIT091 int. 42.5mm

MAGNETOSTRICTIVE TRANSDUCER CONNECTORS WITH ALUMINIUM PROFILE

			WPG-A	WPP-A	WPP-S	WPA-A	WPL-A	WPA-S	MK4-C	MK4-P	WPA-F
CON069	4 PIN EV	IP67	X								
CON006	4 PIN EV	IP65	X								
CON031	5 PIN M12	IP67	X	X		X	X		X		X
CON041	5 PIN M12 90°	IP67	X	X		X	X		X		X
CON035	8 PIN M12	IP67		X	X	X		X			
CON042	8 PIN M12 90°	IP67		X	X	X		X			
CON117	8 PIN M12 90° (UL)	IP67		X	X	X		X			
CON021	6 PIN M16	IP40		X	X	X		X	X		
CON022	6 PIN M16	IP67		X	X	X		X	X		
CON118	6 PIN M16 (UL)	IP67		X	X	X		X	X		
CON023	6 PIN M16 90°	IP67		X	X	X		X	X		
CON026	7/8 PIN M16	IP40		X	X	X		X			
CON027	7/8 PIN M16	IP67		X	X	X		X			
CON028	7/8 PIN M16 90°	IP67		X	X	X		X			
CAV011	M12 5 PIN CABLE 2M.	IP67	X	X		X			X		X
CAV021	M12 5 PIN 90° CABLE 2M.	IP67	X	X		X			X		X
CAV002	M12 8 PIN CABLE 2M.	IP67		X	X	X		X			
CAV005	M12 8 PIN 90° CABLE 2M.	IP67		X	X	X		X			
CON380	5 PIN M12 M.	IP67								X	
CON390	5 PIN M12 F.	IP67								X	
CON089	4 PIN M12 M. COD. D	IP67									X
PCAV700	M8 4 PIN CABLE 3M.	IP67								X	
PCAV702	M8 F. 5 PIN CABLE 3M.	IP67								X	
PCAV703	M8 M. 5 PIN CABLE 3M.	IP67								X	
CAV501	2 (M/F) M12 5 PIN CABLE 2M.	IP67					X				
CAV502	2 (M/F) M12 5 PIN CABLE 5M.	IP67					X				
CAV503	2 (M/F) M12 5 PIN CABLE 10M.	IP67					X				

MAGNETOSTRICTIVE POSITION TRANSDUCERS

MAIN TECHNICAL CHARACTERISTICS





MODEL	WRG-A	WRP-A	WRP-S
USEFUL ELECTRICAL STROKE	50...1500 mm	50...2500 mm	50...2500 mm
INDEPENDENT LINEARITY	± 0...04%	± 0.02%... ± 0.04%	≤ ± 0...02%
RESOLUTION	infinite (limited only by output noise)	16 bit (Max. noise 5 mVpp)	20 μm - 40 μm
REPEATABILITY	< 0.02 mm	< 0.01 mm	< 0.01 mm
SAMPLING TIME	1 ms to 1.5 ms (depending on stroke)	0.5 ms to 2 ms (depending on stroke)	0.5 ms to 4 ms (depending on stroke)
PROPERTIES OF MEASUREMENT PRINCIPLE	Magnetostrictive ultrasonic time measurement (system without physical contact)	Magnetostrictive ultrasonic time measurement (system without physical contact)	Magnetostrictive ultrasonic time measurement (system without physical contact)
OPERATING TEMPERATURE	-20...+75°C	-30...+75°C	-30...+90°C
STORAGE TEMPERATURE	-40...+100°C	-40...+100°C	-40...+100°C
POSITION READER SHIFT SPEED	≤ 10 m/s	≤ 10 m/s	≤ 10 m/s
SLIDING CURSOR SHIFT FORCE	≤ 1N	≤ 1N	≤ 1N
LIFESPAN	Theoretically unlimited	Theoretically unlimited	Theoretically unlimited
TRANSDUCER BODY CONSTRUCTION MATERIAL	Stainless steel 316 Anodised aluminium	Stainless steel 316 Anodised aluminium	Stainless steel 316 Anodised aluminium
POSITION READER CONSTRUCTION MATERIAL	Floating Magnet Slider - Plastroferrite	Floating Magnet Slider - Plastroferrite	Floating Magnet Slider - Plastroferrite
ELECTRICAL CONNECTIONS	WRG-A-M Conn. 4 poles EN175301-803* WRG-A-A Conn. 5 poles M12	WRP-A-A Conn. 5 poles M12 M. WRP-A-B Conn. 6 poles M16 M. WRP-A-C Conn. 8 poles M16 M. WRP-A-H Conn. 8 poles M12 M. WRP-A-F 6-wire PVC cable 1 m. WRP-A-R 7-wire PUR cable 1 m.	WRP-S-B Conn. 6 poles M16 M. WRP-S-C Conn. 8 poles M16 M. WRP-S-D Conn. 7 poles M16 M. WRP-S-H Conn. 8 poles M12 M. WRP-S-F 6-wire PVC cable 1 m. WRP-S-R 7-wire PUR cable 1 m.
OUTPUT SIGNALS	Analogue 1 position cursor	Analogue 2 position cursor	SSI 1 position cursor
PROTECTION RATING	IP67	IP67	IP67
MECHANICS AND ANCHORAGE	Mechanical anchorage with external threaded flange M18x1.5 (standard) (M) 3/4" - 16UNF (F)	Mechanical anchorage with external threaded flange M18x1.5 (standard) (M) 3/4" - 16UNF (F)	Mechanical anchorage with external threaded flange M18x1.5 (standard) (M) 3/4" - 16UNF (F)
HOUSING SIZE/LENGTH	228...1683 mm	228...2683 mm	228...2683 mm

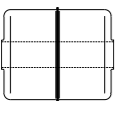
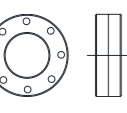

WRA-A	WRA-S	IK4-C	IK4-P	WRA-F
50...4000 mm	50...4000 mm	50...4000 mm	50...4000 mm	50...4000 mm
± 0.01%... ± 0.04%	± 0.01%... ± 0.02%	± 0.02%... ± 0.04%	± 0.01%... ± 0.02%	± 0.01%... ± 0.02%
16 bit (Max. noise 5 mVpp)	0.5 μm - 40 μm	2 μm - 40 μm	1 μm	0.5 μm
< 0.01 mm	< 0.01 mm	< 0.01 mm	< 0.01 mm	< 0.01 mm
0.5 ms to 3 ms (depending on stroke)	0.5 ms to 4 ms (depending on stroke)	1 ms to 4 ms (depending on stroke)	1 ms to 4 ms (depending on stroke)	0.5ms to 3ms (depending on stroke)
Magnetostrictive ultrasonic time measurement (system without physical contact)	Magnetostrictive ultrasonic time measurement (system without physical contact)	Magnetostrictive ultrasonic time measurement (system without physical contact)	Magnetostrictive ultrasonic time measurement (system without physical contact)	Magnetostrictive ultrasonic time measurement (system without physical contact)
-30...+85°C	-30...+90°C	-30...+75°C	-40...+85°C	-40...+85°C
-40...+100°C	-40...+100°C	-40...+100°C	-40...+100°C	-40...+100°C
≤ 10 m/s	≤ 10 m/s	≤ 10 m/s	≤ 10 m/s	≤ 10 m/s
≤ 1N	≤ 1N	≤ 1N	≤ 1N	≤ 1N
Theoretically unlimited	Theoretically unlimited	Theoretically unlimited	Theoretically unlimited	Theoretically unlimited
Stainless steel 316 Anodised aluminium	Stainless steel 316 Anodised aluminium	Stainless steel 316 Anodised aluminium	Stainless steel 316 Anodised aluminium	Anodised aluminium Nickel-plated zamak
Floating magnet slider - Plastroferrite	Floating magnet slider - Plastroferrite	Floating magnet slider Anodised aluminium	Floating magnet slider Anodised aluminium	Magnetic cursor nylon 66 gf 40floating sliding cursor
WRA-A-A Conn. 5 poles M12 M. WRA-A-B Conn. 6 poles M16 M. WRA-A-C Conn. 8 poles M16 M. WRA-A-H Conn. 8 poles M12 M. WRA-A-F 6-wire PVC cable 1 m. WRA-A-R PUR 7-wire cable 1 m.	WRA-S-B Conn. 6 poles M16 M. WRA-S-C Conn. 8 poles M16 M. WRA-S-D Conn. 7 poles M16 M. WRA-S-H Conn. 8 poles M12 M. WRA-S-F 6-wire PVC cable 1 m. WRA-S-R 7-wire PUR cable 1 m.	MK4C-B Conn. 5 poles M12 M. MK4C-A Conn. 6 poles M16 M. MK4C-F4 -wire cable 1 metre	MK4P-W Conn. 5 poles M12 F. MK4P-W Conn. 4 poles M8 M. MK4P-W Conn. 5 poles M12 M.	WRA-F Conn. 5 poles M12 F. (cod. D) WRA-F Conn. 4 poles M8 M. (cod. A) WRA-F Conn. 5 poles M12 M. (cod. D)
Analogue 2 position and speed cursors	SSI 1 position cursor	CANopen 2 position and speed cursors 4 digital cams	PROFIBUS 4 position and speed sliders 4 digital cams	PROFINET 16 position and speed cursors (General Profile) 1 position and speed cursors (Encoder Profile)
0-10Vdc/10-0Vdc 0.1-10.1Vdc/10.1-0.1Vdc 0-20mA/20-0mA 4-20mA/20-4mA	24 bit (Bin./Gray) 25 bit (Bin./Gray) 21+1 bit (Bin./Gray) (FM357)	CANopen DS-301 Interface V4.01 Device Profile	DPV0 Profibus interface on RS485 according to IEC 61158	IO Profinet interface RT & RTI protocol General Profile Encoder Vr. 4.2 Profile
IP67	IP67	IP67	IP67	IP67
Mechanical anchorage with external threaded flange M18x1.5 (standard) (M) 3/4" - 16UNF (F)	Mechanical anchorage with external threaded flange M18x1.5 (standard) (M) 3/4" - 16UNF (F)	Mechanical anchorage with external threaded flange M18x1.5 (standard) (M) 3/4" - 16UNF (F)	Mechanical anchorage with external threaded flange M18x1.5 (standard) (M) 3/4" - 16UNF (F)	Mechanical anchorage with external threaded flange M18x1.5 (standard) (M) 3/4" - 16UNF (F)
228...4183 mm	228...4183 mm	238...4188 mm	233...4188 mm	237...4192 mm

CURSORS POSITION READERS

		WRG-A	WRP-A	WRP-S	WRA-A	WRA-S	IK4-C	IK4-P	WRA-F	RK2	RK4	RK5-A	RK5-C
	Ø32 x Ø13,5 x H7,9mm.	PCUR095	PCUR095	PCUR095	PCUR095	PCUR095	PCUR022	PCUR610	PCUR095	PCUR022	PCUR022		
	Ø32 x Ø13,5 x H7,9mm.	PCUR096	PCUR096	PCUR096	PCUR096	PCUR096	PCUR023	PCUR023	PCUR096	PCUR023	PCUR023		
	Ø25,4 x Ø13,5 x H7,9mm.	PCUR097	PCUR097	PCUR097	PCUR097	PCUR097	PCUR024	PCUR600	PCUR097	PCUR024	PCUR024		
	Ø44 x Ø12 x H52,4mm. AISI 316	PCUR098	PCUR098	PCUR098	PCUR098	PCUR098	PCUR026	PCUR026	PCUR098	PCUR026	PCUR026		
	Ø42 x Ø15 x H52,4mm. AISI 316						PCUR027	PCUR027		PCUR027	PCUR027		
	Ø25,4 x Ø13,5 x H8mm.											PKIT528	PKIT528
	Ø33 x Ø13,5 x H8mm.											PKIT529	PKIT529
	P + M											PKIT525	PKIT525
	P + M + P											PKIT526	PKIT526
	P + M + A											PKIT527	PKIT527

P - Plastic

M - Magnet

A - AISI 420 stainless steel

GEFRAN'S UNIQUE COMPREHENSIVE RANGE

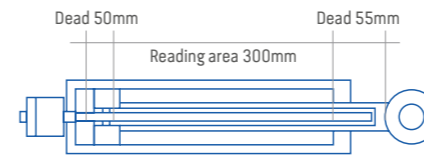

WRG/WRP/WRA Solution 1

**CONTACTLESS,
REPLACE ALL
BRANDS**

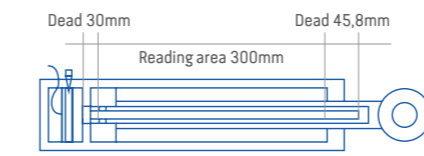

RK5 Solution 2

**CONTACTLESS,
NO WEAR**

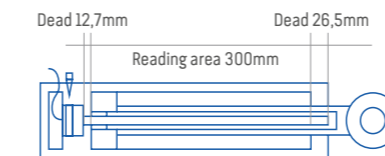

PMI-SL Solution 3

**COMPACT,
ATEX
COMPLIANT**

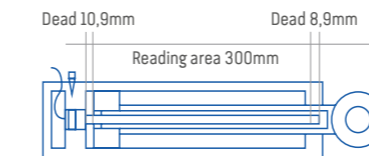

IC Solution 4

**SUPER
COMPACT**

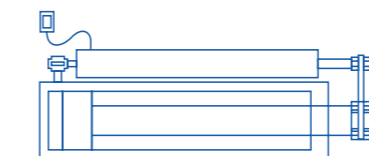

PC67 Solution 5

**AUTO
ALIGNEMENT,
IP67**

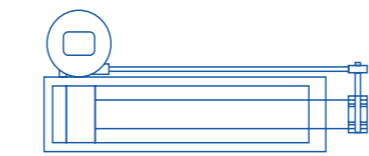

GSH Solution 6

**SMALL WITH
VERY LONG
STROKE**

Gefran is the only sensor manufacturer in the world to offer such a complete range of solutions for detecting the position of the piston in a hydraulic or pneumatic cylinder.

Some transducers are designed to be fully integrated in the cylinders, while others are partially integrated or totally external. The sensors are designed for different uses: steelmaking, industry, self-propelled vehicles, and for use in potentially explosive areas.

All this to meet the needs of a variety of applications: from sensors fully protected against external agents to easily replaceable sensors, identifying the needs with our customers' engineers.

Gefran is in daily contact with the world's leading cylinder manufacturers, studying the best way to integrate sensors into their projects with them. Gefran assesses correct sensor installation with experienced mechanical engineers.

MAGNETOSTRICTIVE POSITION TRANSDUCERS

MAIN TECHNICAL CHARACTERISTICS



MODEL	RK2	RK4	RK5-A
USEFUL ELECTRICAL STROKE	50...4000 mm	50.....4000 mm	50...2500 mm
INDEPENDENT LINEARITY	< ± 0.02% F.S. (minimum ± 0.060 mm)	< ± 0.02% F.S. (minimum ± 0.060 mm)	< ± 0.04% F.S. (minimum ± 0.10 mm)
RESOLUTION	Infinite	Infinite	Infinite
REPEATABILITY	< 0.01 mm	< 0.01 mm	< 0.01 mm
SAMPLING TIME	1 ms to 2 ms (depending on stroke)	1 ms to 2 ms (depending on stroke)	1 ms to 2 ms (depending on stroke)
PROPERTIES OF MEASUREMENT PRINCIPLE	Magnetostrictive ultrasonic time measurement (system without physical contact)	Magnetostrictive ultrasonic time measurement (system without physical contact)	Magnetostrictive ultrasonic time measurement (system without physical contact)
OPERATING TEMPERATURE	- 55...+100°C	- 55...+100°C	- 55...+100°C
STORAGE TEMPERATURE	- 55...+125°C	- 55...+125°C	- 55...+125°C
POSITION READER SHIFT SPEED	≤ 600 rpm	≤ 600 rpm	≤ 600 rpm
SLIDING CURSOR SHIFT FORCE	≤ 0.20 NCM	≤ 1.8 NCM	≤ 0.20 NCM
LIFESPAN	Theoretically unlimited	Theoretically unlimited	Theoretically unlimited
TRANSDUCER BODY CONSTRUCTION MATERIAL	Stainless steel 316	Stainless steel 316	Stainless steel 316
POSITION READER CONSTRUCTION MATERIAL	Magnetic cursor Floating Anodised aluminium	Magnetic cursor Floating Anodised aluminium	Magnetic cursor Floating Anodised aluminium
ELECTRICAL CONNECTIONS	RK2 PUR 8-wire cable 1 m.	RK4 Conn. 5 poles M12 M.	RK5-A Conn. 5 poles M12 M.
OUTPUT SIGNALS	Analogue 1 position cursor	Analogue 1 position cursor	Analogue 1 position cursor
	0.1-10.1Vdc/10.1-0.1Vdc 0.1-5.1Vdc/5.1-0.1Vdc 4-20mA/20-4mA	0.1-10.1Vdc/10.1-0.1Vdc 0.1-5.1Vdc/5.1-0.1Vdc 0-20mA/20-0mA 4-20mA/20-4mA	0.5-9.5Vdc/9.5-0.5Vdc 0.5-4.5Vdc/4.5-0.5Vdc 0-20mA/20-0mA 4-20mA/20-4mA
PROTECTION RATING	IP67	IP67	IP69K
MECHANICS AND ANCHORAGE	Mechanical anchorage with ø33mm internal flange	Mechanical anchorage with external threaded flange M18x1.5 (standard) (M) 3/4" - 16UNF (F)	Mechanical anchorage with ø48mm internal flange
HOUSING SIZE/LENGTH	182 ... 4182 mm	190 ... 4190 MM	154.7 ... 2609.7 mm



MODEL	RK5-C	RK2 XL319
USEFUL ELECTRICAL STROKE	50...2500 mm	50...1000 mm
INDEPENDENT LINEARITY	< ± 0.04% F.S. (minimum ± 0.10 mm)	< ± 0.02% F.S. (minimum ± 0.060 mm)
RESOLUTION	Infinite	Infinite
REPEATABILITY	< 0.01 mm	< 0.01 mm
SAMPLING TIME	1 ms to 2 ms (depending on stroke)	1 ms to 2 ms (depending on stroke)
PROPERTIES OF MEASUREMENT PRINCIPLE	Magnetostrictive ultrasonic time measurement (system without physical contact)	Magnetostrictive ultrasonic time measurement (system without physical contact)
OPERATING TEMPERATURE	- 55...+100°C	- 55...+100°C
STORAGE TEMPERATURE	- 55...+125°C	- 55...+125°C
POSITION READER SHIFT SPEED	≤ 600 rpm	≤ 600 rpm
SLIDING CURSOR SHIFT FORCE	≤ 0.20 NCM	≤ 0.20 NCM
LIFESPAN	Theoretically unlimited	Theoretically unlimited
TRANSDUCER BODY CONSTRUCTION MATERIAL	Stainless steel 316	Stainless steel 316 Anodised aluminium
POSITION READER CONSTRUCTION MATERIAL	Floating Magnet Slider Ferrobore Neodymium	Floating magnet slider Anodised aluminium
ELECTRICAL CONNECTIONS	RK5-C Conn. 5 poles M12 M.	RK2 PUR 8-wire cable 1 m.
OUTPUT SIGNALS	Analogue 1 position cursor	Analogue 1 position cursor
	CANopen DS-301 Interface V4.01 Device Profile	*RK2 XL319 0-10Vdc/10-0VdcRK2 XL353 4-20mA/20-4mA*
PROTECTION RATING	IP69K	IP67
MECHANICS AND ANCHORAGE	Mechanical anchorage with ø48mm internal flange	Mechanical anchorage and self-aligning drive on two self-aligning ball joints.
HOUSING SIZE/LENGTH	154.7 ... 2609.7 mm	250 ... 1200 mm closed rod 302 ... 2202 mm open rod

MAGNETOSTRICTIVE TRANSDUCER CONNECTORS



POSITION TRANSDUCERS

			WRG-A	WRP-A	WRP-S	WRA-A	WRA-S	IK4-C	IK4-P	WRA-F	RK4	RK5-A	RK5-C
CON069	4 PIN EV	IP67	X										
CON006	4 PIN EV	IP65	X										
CON031	5 PIN M12 (UL)	IP67	X	X		X		X		X	X	X	X
CON041	5 PIN M12 90° (UL)	IP67	X	X		X		X		X	X	X	X
CON035	8 PIN M12 (UL)	IP67		X	X	X	X						
CON042	8 PIN M12 90°	IP67		X	X	X	X						
CON117	8 PIN M12 90° (UL)	IP67		X	X	X	X						
CON021	6 PIN M16	IP40		X	X	X	X	X					
CON022	6 PIN M16	IP67		X	X	X	X	X					
CON118	6 PIN M16 (UL)	IP67		X	X	X	X	X					
CON023	6 PIN M16 90°	IP67		X	X	X	X	X					
CON026	7/8 PIN M16	IP40		X	X	X	X						
CON027	7/8 PIN M16	IP67		X	X	X	X						
CON028	7/8 PIN M16 90°	IP67		X	X	X	X						
CAV011	M12 5 PIN CABLE 2M.	IP67	X	X		X		X		X	X	X	X
CAV021	M12 5 PIN 90° CABLE 2M.	IP67	X	X		X		X		X	X	X	X
CAV002	M12 8 PIN CABLE 2M.	IP67		X	X	X	X						
CAV005	M12 8 PIN 90° CABLE 2M.	IP67		X	X	X	X						
CON380	5 PIN M12 M. PROFIBUS	IP67							X				
CON390	5 PIN M12 F. PROFIBUS	IP67							X				
CON089	4PIN M12 M. COD. D	IP67								X			
PCAV700	M8 4 PIN CABLE 3M.	IP67							X				
PCAV702	M8 F. 5 PIN CABLE 3M.	IP67							X				
PCAV703	M8 M. 5 PIN CABLE 3M.	IP67							X				

POTENTIOMETRIC POSITION TRANSDUCERS

MAIN TECHNICAL CHARACTERISTICS



MODEL	LT /LT67	PC / PC67	PK
USEFUL ELECTRICAL STROKE	50...900 mm	50...750 mm	100...2000 mm
INDEPENDENT LINEARITY	±0.05%	±0.05%	±0.05%
RESOLUTION	Infinite	Infinite	Infinite
REPEATABILITY	< 0.01 mm	< 0.01 mm	< 0.01 mm
RESISTANCE	5K0hm / 50...600 10K0hm / 750...900	5K0hm / 50...600	5K0hm / 100...300 10K0hm / 400...1000 20K0hm / 1250...2000
OPERATING TEMPERATURE	-30...+100°C	-30...+100°C	-30...+100°C
STORAGE TEMPERATURE	-50...+120°C	-50...+120°C	-50...+120°C
SHIFT SPEED	LT ≤ 10 M/S LT67 ≤ 3 M/S MAX ≤ 5 M/S	PC ≤ 5 M/S, PC67 ≤ 3M/S MAX ≤ 5M/S	≤ 10 M/S
SHIFT FORCE	LT-S ≤ 3.5N (IP60) LT-P ≤ 10N (IP65) LT67 ≤ 20N (IP67)	PC ≤ 15N PC67 ≤ 30N	≤ 1.2N
LIFESPAN	> 100 x 10 ⁶ manoeuvres	> 100 x 10 ⁶ manoeuvres	> 100 x 10 ⁶ manoeuvres
TRANSDUCER BODY CONSTRUCTION MATERIAL	Anodised aluminium Nylon 66 GF 40	Anodised aluminium Nylon 66 GF 40	Anodised aluminium Nylon 66 GF 40
DRIVE SHAFT CONSTRUCTION MATERIAL	Stainless steel AISI 303	Stainless steel AISI 303	Nylon Cursor 66 GF 40 Latilub 73/13
PROTECTION RATING	LT/S IP60 LT/P IP6 LT67 IP67	PC IP65 PC67 IP67	IP40
MECHANICS AND ANCHORAGE	Mechanical drive with M6 threaded shaft, anchorage brackets with variable centre-to-centre distance.	Mechanical anchorage and self-aligning drive on two self-aligning ball joints.	Mechanical drive with joint for taking up play, M5 thread anchorage brackets with variable centre-to-centre distance.
DIMENSIONS / HOUSING LENGTH	112...977 mm	185...898 mm	253...2171 mm
	 RoHS ✓ Ex VR.XL339	 RoHS ✓ Ex VR.XL339	 RoHS ✓ Ex VR.XL339

POSITION TRANSDUCERS



MODEL	PA1	PV1	PV2	PV3
USEFUL ELECTRICAL STROKE	25...150 mm	25...150 mm	10...150 mm	25...150 mm
INDEPENDENT LINEARITY	± 0.2%/25 ± 0.1%/50...100 ± 0.05%/125...150	± 0.2%/25 ± 0.1%/50...100 ± 0.05%/125...150	± 0.3%/10 ± 0.2%/25 ± 0.1%/50	± 0.2%/25 ± 0.1%/50
RESOLUTION	Infinite	Infinite	Infinite	Infinite
REPEATABILITY	< 0.01 mm	< 0.01 mm	< 0.01 mm	< 0.01 mm
RESISTANCE	1K0hm / 25 5K0hm / 50...150	1K0hm / 25 5K0hm / 50...150	1K0hm / 10...25 mm 5K0hm / 50...150 mm	1K0hm / 25 mm 5K0hm / 50...150 mm
OPERATING TEMPERATURE	-30...+100°C	-30...+100°C	-30...+100°C	-30...+100°C
STORAGE TEMPERATURE	-50...+120°C	-50...+120°C	-50...+120°C	-50...+120°C
SHIFT SPEED	≤ 5 M/S	≤ 10 M/S	≤ 10 M/S	≤ 10 M/S
SHIFT FORCE	≤ 1.2N	≤ 0.3N	≤ 0.4N	≤ 0.4N
LIFESPAN	> 100 x 10 ⁶ manoeuvres	> 100 x 10 ⁶ manoeuvres	> 100 x 10 ⁶ manoeuvres	> 100 x 10 ⁶ manoeuvres
TRANSDUCER BODY CONSTRUCTION MATERIAL	Anodised aluminium Nylon 66 GF 40	Anodised aluminium Nylon 66 GF 40	Anodised aluminium Nylon 66 GF 40	Anodised aluminium Nylon 66 GF 40
DRIVE SHAFT CONSTRUCTION MATERIAL	AISI 303 stainless steel	AISI 303 stainless steel	AISI 303 stainless steel	AISI 303 stainless steel
PROTECTION RATING	IP40	IP40	IP40	IP40
MECHANICS AND ANCHORAGE	Mechanical drive with joint for taking up play, M4 thread, anchorage brackets with variable centre-to-centre distance.	Probe shaft with joint for taking up play, M4 thread, anchorage brackets with variable centre-to-centre distance.	Probe shaft with double support and return spring. Ball point. Anchorage brackets with variable centre-to-centre distance.	Probe shaft with double support and return spring. Locked against rotation. Ball bearing tip. Anchorage brackets with variable centre-to-centre distance.
DIMENSIONS / HOUSING LENGTH	74.5...199.5 mm	63...188 MM	48...188 mm	63...188 mm
	 RoHS ✓ Ex VR.XL339	 RoHS ✓ Ex VR.XL339	 RoHS ✓ Ex VR.XL339	 RoHS ✓ Ex VR.XL339

POTENTIOMETRIC POSITION TRANSDUCERS

MAIN TECHNICAL CHARACTERISTICS



MODEL	PZ12	PZ34/PZ67	IC	PME12
USEFUL ELECTRICAL STROKE	25...150 mm	25,250 mm	100,550 mm	50,1000 mm
INDEPENDENT LINEARITY	± 0.2% / 25 ± 0.1% / 50...10 ± 0.05% / 125...150	± 0.2% / 25 ± 0.1% / 50...100 ± 0.05% / 125...250	± 0.1%	± 0.1% / 50...100mm ± 0.05% / 150...1000mm
RESOLUTION	Infinite	Infinite	Infinite	Infinite
REPEATABILITY	< 0.01 mm	< 0.01 mm	< 0.01 mm	< 0.08 mm
RESISTANCE	1K0hm / 25 2K0hm / 50mm 3K0hm / 75 4K0hm / 100mm 5K0hm / 125 6K0hm / 150mm	1K0hm / 25 2K0hm / 50mm 3K0hm / 75 4K0hm / 100mm 5K0hm / 125 6K0hm / 150mm 8K0hm / 200 10K0hm / 250mm	10K0hm	5K0hm / 50...300 10K0hm / 350...600 20K0hm / 650...1000
OPERATING TEMPERATURE	-30...+100°C	-30...+100°C	-30...+100°C	-30...+100°C
STORAGE TEMPERATURE	-50...+120°C	-50...+120°C	-50...+120°C	-50...+120°C
SHIFT SPEED	≤ 10 M/S	≤ 10 M/S	≤ 1.5 M/S	≤ 10 M/S
SHIFT FORCE	≤ 0.5N	≤ 0.5N	≤ N	≤ 0.5N
LIFESPAN	> 100 x 10 ⁶ manoeuvres	> 100 x 10 ⁶ manoeuvres	> 100 x 10 ⁶ manoeuvres	> 100 x 10 ⁶ manoeuvres
TRANSDUCER BODY CONSTRUCTION MATERIAL	Anodised aluminium Nylon 66 GF 40	PZ34: Anodised aluminium Nylon 66 GF 40 PZ67: Steel C45, chrome-plated 20mm	Rod: Anodised aluminium	Anodised aluminium 12.7 mm diameter rod, Nylon 66 GF 40 cursor
DRIVE SHAFT CONSTRUCTION MATERIAL	AISI 303 stainless steel	AISI 303 stainless steel	Flange: AISI 303 stainless steel	Nylon 66 GF 40
ELECTRICAL CONNECTIONS	Shielded cable 3-pole 3x0.25-1m	Shielded cable 3-pole 3x0.25-1m	ICC conn. 5-pole ICF 3 wires - 200 mm	PME12C conn. 3-pole PME12F 3-pole cable x0.25 - 1m
PROTECTION RATING	IP60	PZ34 IP60 PZ67 IP67		IP67
MECHANICS AND ANCHORAGE	PZ12-S Mechanical with brackets PZ12-A Self-aligning joints PZ12-F flange	PZ34-S Mechanical with brackets PZ34-A Self-aligning joints PZ34-F flange PZ67 Self-aligning joints	Mechanical anchorage with internal or external flange	Mechanical with brackets
DIMENSIONS / HOUSING LENGTH	74.5...199.5 mm	83.5...308.5 mm	max. 123.5...573.5 mm	55...1065 mm
	 VR. XL339	 VR. XL339	 VR. XL339	 VR. XL339



MODEL	PMA12	PMI12	PMI-SL/PMI-SLE
USEFUL ELECTRICAL STROKE	50...1000 mm	50...1000 mm	50...1000 mm
INDEPENDENT LINEARITY	± 0.1% / 50...100mm ± 0.05% / 150...1000mm	± 0.1% / 50...100mm ± 0.05% / 150...1000mm	± 0.1% / 50...100mm ± 0.05% / 150...1000mm
RESOLUTION	Infinite	Infinite	Infinite
REPEATABILITY	≤ 0.08 mm	≤ 0.08 mm	≤ 0.08 mm
RESISTANCE	5K0hm / 50...300 10K0hm / 350...600 20K0hm / 650...1000	*5K0hm / 50...300 10K0hm / 350...600 20K0hm / 650...1000	5K0hm / 50...300 10K0hm / 350...600 20K0hm / 650...1000
OPERATING TEMPERATURE	-30...+100°C	-30...+100°C	-30...+100°C
STORAGE TEMPERATURE	-50...+120°C	-50...+120°C	-50...+120°C
SHIFT SPEED	≤ 10 M/S	≤ 10 M/S	≤ 10 M/S
SHIFT FORCE	≤ 0.5N	≤ 0.5N	≤ 0.5N
LIFESPAN	> 100 x 10 ⁶ manoeuvres	> 100 x 10 ⁶ manoeuvres	> 100 x 10 ⁶ manoeuvres
TRANSDUCER BODY CONSTRUCTION MATERIAL	Anodised aluminium Nylon 66 GF 40	Stainless steel rod diameter 16 mm	Stainless steel rod diameter 12.7 mm
DRIVE SHAFT CONSTRUCTION MATERIAL	Nylon 66 GF 40	Nylon 66 GF 40	Nylon 66 GF 40
ELECTRICAL CONNECTIONS	3-pole cable x0.25 - 1m	3-pole cable x0.25 - 1m	PMI-SL voltage divider potentiometer output, 3-pole cable x0.25 - 1m PMI-SLE 4...20mA output, 3-pole cable x0.25 - 1m
PROTECTION RATING	IP67	IP68	IP68
MECHANICS AND ANCHORAGE	Self-aligning joints	Mechanical anchorage with internal or external flange	Mechanical anchorage with internal or external flange
DIMENSIONS / HOUSING LENGTH	205...1155 mm	55...1097 mm	55...1100 mm
	 VR. XL339	 VR. XL339	 PMI-SL VR. XL339

POTENTIOMETRIC ROTARY POSITION TRANSDUCERS

MAIN TECHNICAL CHARACTERISTICS



MODEL	PS09	PS11	PS20	PR65
USEFUL ELECTRICAL STROKE	340° ± 4°	345° ± 4°	350° ± 4°	345° ± 4°
INDEPENDENT LINEARITY	±1...±0.05%	±1...±0.05%	±1...±0.05%	±1...±0.05%
RESOLUTION	Infinite	Infinite	Infinite	Infinite
TOTAL RESISTANCE (+/-20%)	1 / 4.7 / 10K0hm	2 / 4.7 / 10K0hm	3 / 4.7 / 10K0hm	4 / 4.7 / 10K0hm
OPERATING TEMPERATURE	-55...+100°C	-55...+100°C	-55...+100°C	-55...+100°C
STORAGE TEMPERATURE	-55...+125°C	-55...+125°C	-55...+125°C	-55...+125°C
SPEED OF ROTATION	≤ 600 rpm	≤ 600 rpm	≤ 600 rpm	≤ 600 rpm
SHAFT TORQUE	≤ 0.20 Ncm	≤ 0.20 Ncm	≤ 0.20 Ncm	≤ 1.8 Ncm
LIFESPAN	> 100 x 10 ⁶ manoeuvres	> 100 x 10 ⁶ manoeuvres	> 100 x 10 ⁶ manoeuvres	> 100 x 10 ⁶ manoeuvres
TRANSDUCER BODY CONSTRUCTION MATERIAL	DAP	DAP	DAP	Nylon 66 GF 30
DRIVE SHAFT CONSTRUCTION MATERIAL	Stainless steel AISI 303	Stainless steel AISI 303	Stainless steel AISI 303	Stainless steel AISI 303
ELECTRICAL CONNECTIONS	Welded turrets	Welded turrets	Welded turrets	Welded turrets
PROTECTION RATING	IP40	IP40	IP40	IP65
MECHANICS AND ANCHORAGE	Servo mounting (flange)	Servo mounting (flange)	Servo mounting (flange)	5-pole connector
DIMENSIONS	External diameter 22,25mm External diameter 3,175mm	External diameter 27,05mm External diameter 3,175mm	External diameter 50,80mm External diameter 6,35mm	External diameter 55 mm External diameter 6 mm
	RoHS✓	RoHS✓	RoHS✓	RoHS✓

CONNECTORS AND ACCESSORIES FOR POTENTIOMETRIC TRANSDUCERS



SIGNAL CONDITIONERS FOR POTENTIOMETRIC TRANSDUCERS



PCIR-101

0...10Vdc output



PCIR-102

4...20mA output



PCIR-A

0...10Vdc output

- Interface module integrated in female connector
- Standard output 0...10Vdc (PCIR 101)
- Standard output 4...20mA (PCIR 102)
- High linearity (0.01% F.S.0)
- Reduced thermal deviation of Zero and Span
- Adjustable Zero and Span
- High input impedance (> 100 M0hm)
- Standard output 0...10Vdc
- Linearity error (0.02% F.S.0)
- Simultaneous processing of two transducers
- Reduced temperature deviation (0.01% F.O.S. / °C)
- Ready for DIN EN50035 and EN50022 mounting
- MOR031 female connector

			LT	PC	PC67	PK	PA1	PV1	PV2	PV3	PME	IC
CON002	3 PIN	IP40	X	X								
CON006	4 PIN	IP65	X			X						
CON008	4 PIN	IP65		X								
CON011	5 PIN	IP40	X	X		X	X	X	X	X		
CON011	5 PIN	IP67	X	X		X	X	X	X	X		
CON011	5 PIN 90°	IP67	X	X		X	X	X	X	X		
CON293	4 PIN M12	IP67			X							
CON050	4 PIN M12 90°	IP67			X							
CAV010	3 PIN	IP67									X	
CON300	6 PIN	IP66										X

POSITION TRANSDUCERS

MAIN TECHNICAL CHARACTERISTICS



MODEL	GRA	GRN	GIB	GIG
USEFUL ELECTRICAL STROKE	±15°-360° (15° step in analogue versions)	±15°-360° (15° step in analogue versions)	±10° ±15° ±20° ±30° ±45° ±60° ±85° (dual XY axis) ±180° (single Z axis)	±10° ±15° ±20° ±30° ±45° ±60° ±85° (dual XY axis) ±180° (single Z axis)
UNIT OF MEASUREMENT:	Angular Degrees	Angular Degrees	Angular Degrees	Angular Degrees
INDEPENDENT LINEARITY	±0.5%FS.	±0.5%FS.	< ±0.5% FS (±10° to ±60°; ±180°); < ±0.5% FS (±85°)	< ±0.5% FS
RESOLUTION	12 bit (analogue output); 4096 14 bit divisions (CAN output); 16384 divisions	12 bit (analogue output); 4096 14 bit divisions (CAN output); 16384 divisions	0.05° (±10° to ±20°); 0.05° (±30°); 0.1° (±45°); 0.1° (±60°); 0.1° (±85°); 0.1° (±180°) analogue; 0.05° for CANopen version	0.05° (±10° to ±20°); 0.05° (±30°); 0.1° (±45°); 0.1° (±60°); 0.1° (±85°); 0.1° (±180°) analogue; 0.05° for CANopen version
SAMPLING TIME	4 msec	4 msec	67 msec	67 msec
PROPERTIES OF MEASUREMENT PRINCIPLE	Hall effect	Hall effect	MEMS technology (Micro-Electro-Mechanical Systems)	MEMS technology (Micro-Electro-Mechanical Systems)
OPERATING TEMPERATURE	-40...+85°C	-40...+85°C	-40...+85°C	-40...+85°C
STORAGE TEMPERATURE	-40...+85°C	-40...+85°C	-40...+85°C	-40...+85°C
LIFESPAN	35 Mil. operations (stroke ±75°)	Theoretically unlimited	Theoretically unlimited	Theoretically unlimited
TRANSDUCER BODY CONSTRUCTION MATERIAL	Transducer: PBT (polybutylene terephthalate)	Transducer: PBT (polybutylene terephthalate)	Transducer: PBT (polybutylene terephthalate)	Transducer: PBT (polybutylene terephthalate)
POSITION READER CONSTRUCTION MATERIAL		Floating Magnetic Cursors 316 L Stainless Steel SmCo Samarium Cobalt		
OUTPUT SIGNALS	Ratiometric, Analogue, CANopen, CAN SAE J1939 0.5-4.5Vdc/4.5-0.5Vdc 0-10Vdc/10-0Vdc 4-20mA/20-4mA CANopen, CAN SAE J1939	Ratiometric, Analogue, CANopen, CAN SAE J1939 0.5-4.5Vdc/4.5-0.5Vdc 0-10Vdc/10-0Vdc 4-20mA/20-4mA CANopen, CAN SAE J1939	Ratiometric, Analogue, CANopen 0.5-4.5Vdc/4.5-0.5Vdc 0-10Vdc/10-0Vdc 4-20mA/20-4mA CANopen	Ratiometric, Analogue, CANopen 0.5-4.5Vdc/4.5-0.5Vdc 0-10Vdc/10-0Vdc 4-20mA/20-4mA CANopen
OUTPUT TYPE	Single / Redundant	Single / Redundant	Single	Single / Redundant
PROTECTION RATING	Output conn. AMP (IP X9K) Output cable (IP 68)	Output conn. AMP (IP X9K) Output cable (IP 68) Output cable +Conn. M12 - 67	Output conn. M12 (IP67) Output cable (IP X9K)	Output conn. M12 (IP67) Output cable (IP X9K)
MECHANICS AND ANCHORAGE	Angular movement detection shaft integral with transducer body 2 anchorage holes	3 anchorage holes	3 anchorage holes	3 anchorage holes
HOUSING SIZE/LENGTH	54.9 x 30.8 x H27.5+13.6 Shaft mm.	65.4 x 43.8 x H14.2 mm	65.4 x 43.8 x H14.2 mm	84 x 70 x H37.9 mm.

POSITION TRANSDUCERS



MODEL	GIG RELAY	GIT	GSF	GSH
USEFUL ELECTRICAL STROKE	±10° ±15° ±20° ±30° ±45° ±60° (dual XY axis)	±10° ±15° ±20° ±30° ±45° ±60° (dual XY axis)	1800-2300-3300-4300-4800-5300-6300-7300-8300	1800-2300-3300-4300-4800-5300-6300-7300-8300
UNIT OF MEASUREMENT:	Angular Degrees	Angular Degrees	mm	mm
INDEPENDENT LINEARITY	< ±0.15% FS	< ±0.15% FS (±15° to ±60°; ±180°); < ±0.3% FS (±85°)	*±0.25% FS (1800mm to 4300mm) ±0.5% FS (4800mm to 8300mm)*	±0.5 %F.S.
RESOLUTION	0.01° (±10° to ±20°); 0.02° (±30°); 0.03° (±45°); 0.04° (±60°)	Analogue outputs 0.01° (±10° to ±20°); 0.02° (±30°); 0.03° (±45°); 0.04° (±60°); 0.05° (±85°); 0.1° (±180°). CANopen output: 0.01°	*infinite for potentiometer output analogue outputs 0.5, 4, 5V, 0, 10V, 4, 20mA 12 bit; CANopen 14/16 bit output	*analogue outputs 0.5, 4, 5V, 0, 10V, 4, 20mA 12 bit; CANopen 14/16 bit output
SAMPLING TIME	67 msec	67 msec	17 msec	17 msec
PROPERTIES OF MEASUREMENT PRINCIPLE	*MEMS technology (Micro-Electro-Mechanical Systems)*	*MEMS technology (Micro-Electro-Mechanical Systems)*	Potentiometer	Hall effect
OPERATING TEMPERATURE	-40...+85°C	-40...+85°C	-40...+85°C	-40...+85°C
STORAGE TEMPERATURE	-40...+85°C	-40...+85°C	-40...+85°C	-40...+65°C
LIFESPAN	Theoretically unlimited	Theoretically unlimited	250,000 cycles (strokes up to 5300mm) otherwise 2,000 km travelled; @ typical speed 1m/s, typical acceleration 1g	500,000 cycles @ typical speed 1m/s, typical acceleration 0.5g 250,000 cycles @ typical speed 2m/s, typical acceleration 1g
TRANSDUCER BODY CONSTRUCTION MATERIAL	Transducer: PBT (polybutylene terephthalate)	Transducer: PBT (polybutylene terephthalate)	*Transducer: PBT Cable: AISI316 stainless steel coated with nylon Ø 0.85mm*	*Transducer: PBT Cable: AISI316 stainless steel coated with nylon Ø 0.85mm*
POSITION READER CONSTRUCTION MATERIAL	-	-	-	-
OUTPUT SIGNALS	Relay output	Ratiometric, Analogue, CANopen	Potentiometric, Analogue, CANopen	Analogue, CANopen
	Relay Output 1 (N.C. / N.O.) Relay Output 2 (N.C. / N.O.)	0.5-4.5Vdc/4.5-0.5Vdc 0-10Vdc/10-0Vdc 4-20mA/20-4mA CANopen	CANopen DS-301 Interface V4.01 Device Profile	DPV0 Profibus interface on RS485 according to IEC 61158
OUTPUT TYPE	Single	Single / Redundant	Single / Redundant	Single / Redundant / Semi-redundant
PROTECTION RATING	Output conn. M12 (IP67) Output cable (IP X9K)	Output conn. M12 (IP67) Output cable (IP X9K)	IP67	IP67
MECHANICS AND ANCHORAGE	3 anchorage holes	4 anchorage holes	Mechanical wire drive with spring return	Mechanical wire drive with spring return
HOUSING SIZE/LENGTH	84 x 70 x H37.9 mm.	66 x 90 x H35.5 mm.	107.5 x 107.5 x H80.5 mm.	107.5 x 107.5 x H65 mm. (1800...6300 mm.) 107.5 x 107.5 x H68 mm. (7300...8300 mm.)

ACCESSORIES

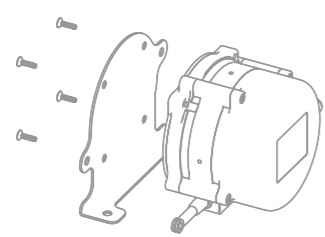

FLANGE MODEL A - FLA033

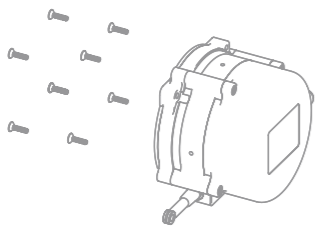

FLANGE MODEL B - FLA034

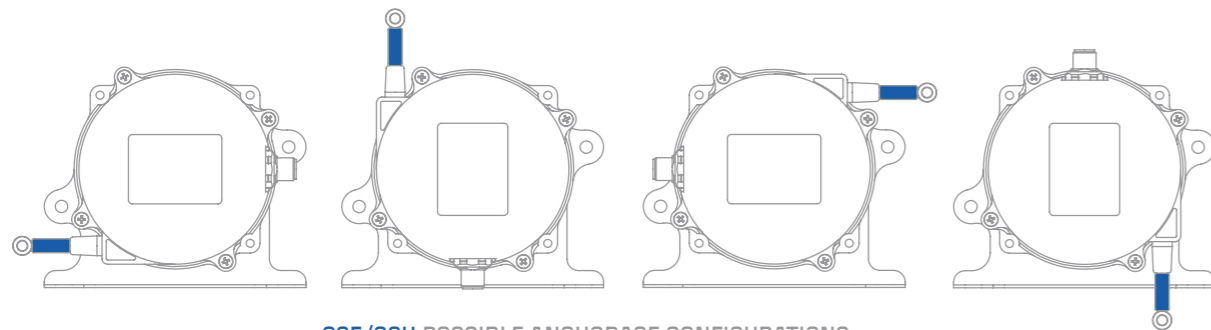
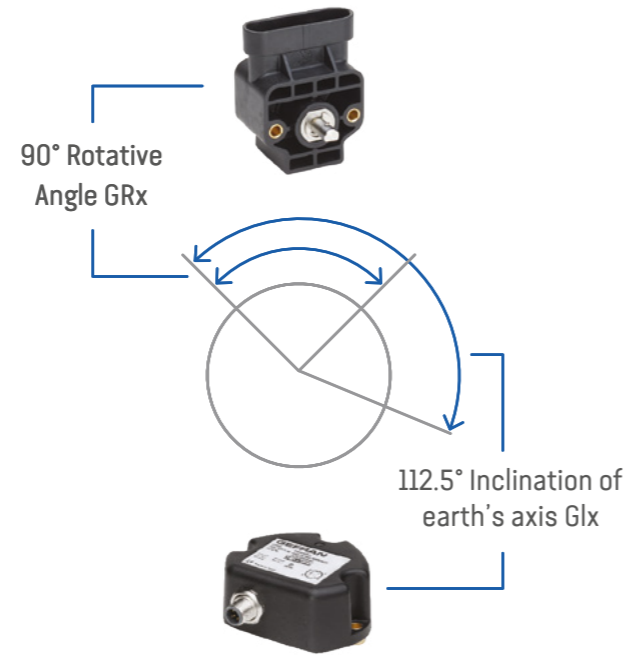

GSF/GSH POSSIBLE ANCHORAGE CONFIGURATIONS

ROTARY TRANSDUCER CONNECTORS, INCLINOMETERS, EXTENSIONS



CAV002



CAV005



CAV011



CAV021



CAV035



CON031



CON041



CON050



CON293



PCON010















PCON013

			GRA	GRN	GIB	GIG	GIG-RELAV	GIT	GSF	GSH
CON293	4 PIN M12	IP67							X	X
CON050	4 PIN M12 90°	IP67							X	X
CON031	5 PIN M12 (UL)	IP67			X					X
CON041	5 PIN M12 90° (UL)	IP67			X					X
CON035	8 PIN M12 (UL)	IP67				X	X	X	X	X
CON042	8 PIN M12 90°	IP67				X	X	X	X	X
CON117	8 PIN M12 90° (UL)	IP67				X	X	X	X	X
CON011	M12 5 PIN CABLE 2M.	IP67			X					X
CON021	M12 5 PIN 90° CABLE 2M.	IP67			X					X
CAV002	M12 8 PIN CABLE 2M.	IP67				X	X	X	X	X
CAV005	M12 8 PIN 90° CABLE 2M.	IP67				X	X	X	X	X
PCON010	PUR 2M CABLE + CONN. 6 PIN DEUTSCH	IP67	X							
PCON013	PUR 2M CABLE + CONN. 6 PIN AMP	IPX9K	X	X	X					

WIDE RANGE OF PRODUCTS ONE FOR EACH APPLICATION

MODEL	TECHNOLOGY	RUN	LINEARITY	RESOLUTION	OUTPUTS	CERTIFICATIONS	
WPG-A	MAGNETOSTRICTIVE	50..1500	± 0.02%	Infinite	Analogue		
WPP-A		50..2500	± 0.02% - ± 0.04%	16 bit			
WPP-S		50..2500	± 0.02%	20 - 40 µm	SSI		
WPA-A		50..4000	± 0.01% - ± 0.04%	16 bit	Analogue	cULus	
WPA-S		50..4000	± 0.01% - ± 0.02%	0,5 - 40 µm	SSI	cULus	
WPL-A		50..4000	± 0.01% - ± 0.02%	5 - 100 µm	IO-Link	cULus	
MK4-C		50..4000	± 0.02% - ± 0.04%	2 - 40 µm	CANopen		
MK4-P		50..4000	± 0.01% - ± 0.02%	1 µm	Profibus		
WPA-F		50..4000	± 0.01% - ± 0.02%	0,5 - 40 µm	Profinet		
WRG-A		50..1500	± 0.02%	Infinite	Analogue		
WRP-A		50..2500	± 0.02% - ± 0.04%	16 bit			
WRP-S		50..2500	± 0.02%	20 - 40 µm	SSI		
WRA-A		50..4000	± 0.01% - ± 0.04%	16 bit	Analogue	cULus	
WRA-S		50..4000	± 0.01% - ± 0.02%	0,5 - 40 µm	SSI	cULus	
IK4C		50..4000	± 0.02% - ± 0.04%	2 - 40 µm	CANopen		
IK4-P		50..4000	± 0.01% - ± 0.02%	1 µm	Profibus		
WRA-F		50..4000	± 0.01% - ± 0.02%	0,5 - 40 µm	Profinet		
RK2		50..4000	± 0.02%	Infinite	Analogue		
RK4		50..4000	± 0.02%				
RK5-A		50..2500	± 0.04%				
RK5-C		50..2500	± 0.04%			CANopen	
RK2 XL319		50..1000	± 0.02%		Analogue		
LT/LT67		POTENTIOMETER	50..900	± 0.05%	Infinite	Potentiometric Voltage Divider	Atex (XI339)
PC/PC67			50..750	± 0.05%			
PK	100..2000		± 0.05%				
PA1	25..150		± 0.2% - ± 0.05%				
PV1	25..150		± 0.2% - ± 0.05%				
PV2	10..250		± 0.3% - ± 0.1%				
PV3	25..150		± 0.3% - ± 0.1%				
PZ12	25..150		± 0.2% - ± 0.05%				
PZ34/PZ67	25..150		± 0.2% - ± 0.05%				
IC	100..550		± 0.1%				
PME12	50..1000		± 0.1% - ± 0.05%				
PMA12	50..1000		± 0.2% - ± 0.05%				
PMI12	50..1000		± 0.2% - ± 0.05%				
PMI-SL/SLE	50..1000		± 0.2% - ± 0.05%				
GSF	POTENTIOMETER	1800..8300	± 0.25% - ± 0.5%	Infinite 12bit - 14/16bi	Potentiometric, Analogue, CANopen, SAE1939		
GSH	HALL EFFECT	1800..8300	± 0.5%				

ENVIRONMENTAL PROTECTION OF POSITION TRANSDUCERS

	4 	6 	6 	6 	6 	6 	
	0 	0 	5 	7 	8 	9k 	
	IP40	IP60	IP65	IP67	IP68	IP69K	
MAGNETOSTRICTIVE				WPG-A	WRG-A		
				WPP-A	WRP-A		
				WPP-S	WRP-S		
				WPA-A	WRA-A		
				WPA-S	WRA-S		
				WPL-A	IK4C		
				MK4C	IK4P		
				MK4P	WRA-F		
				WPA-F	RK2		
				RK2 XL319	RK4		
						RK5-A	
						RK5-C	
	POTENTIOMETERS	PK	LT	LT	LT67	PMI12	
		PA1	PZ12	PC	PC67	PMI-SL	
PY1		PZ34	PR65	PZ67	PMI-SLE		
PY2				PME			
PY3				PMI			
PS09				GSF			
PS11							
PS20							
HALL EFFECT				GRN-F(1)	GRA-D	GRA-A	
				GSH	GRN-F	GRN-A	
INCLINE METERS				GIB-F(1)		GIB-A	
				GIG-M		GIB-F	
				GIT-M		GIG-F	
						GIT-F	

COD.81211N

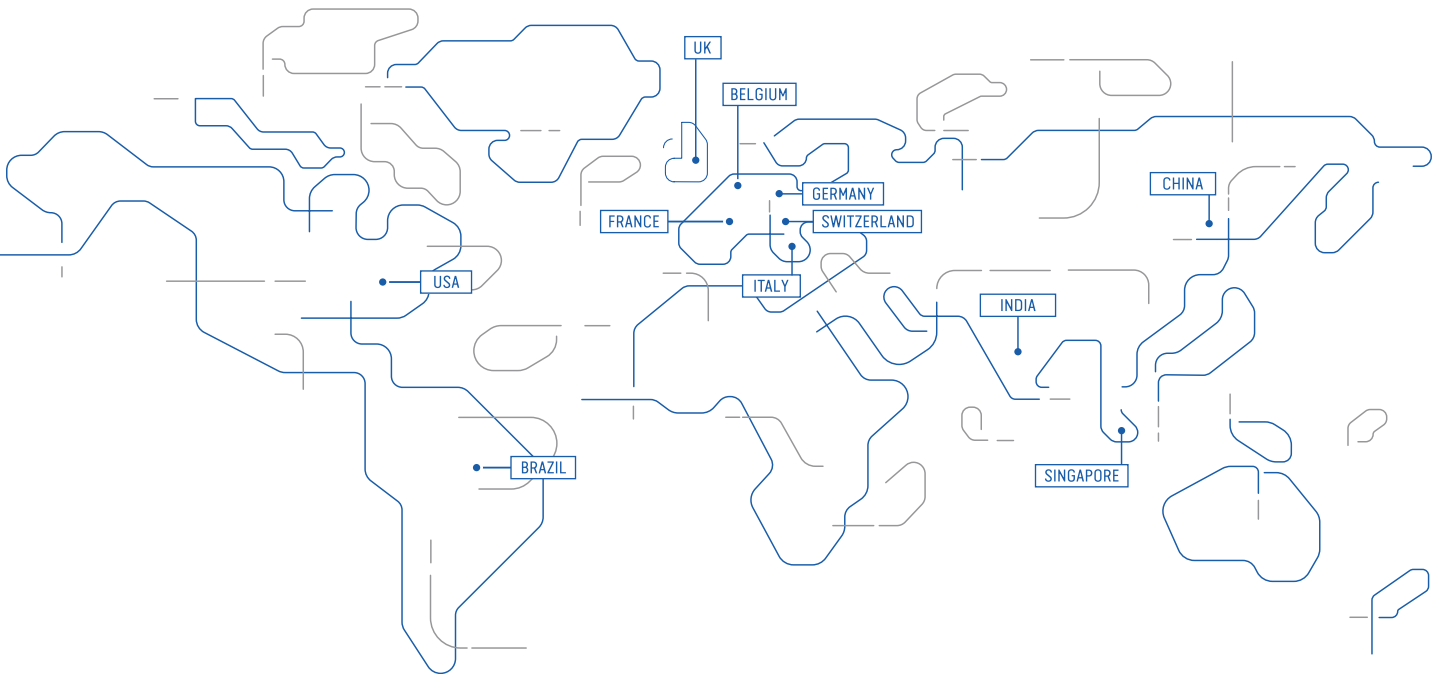

WWW.GEFRAN.COM

